

FLK 费洛卡重工



LSJ 系列拉丝机专用减速机
LSJ series reducer for drawing machine

LSJ系列减速机适用于直进式拉丝机；

LSJ series reducer is suitable for straight wire drawing machine;

LSJ系列减速机外形根据直进式拉丝机安装特点设计，各型号规格尺寸标准并高度统一；

LSJ series reducer is designed by the installation characteristics of the straight wire drawing machine, the specification and dimension of each model is standardized and highly integrated.

LSJ系列减速机与水盘采用一体化设计，水盘内部设有回水孔，水盘外围设有进水孔，确保卷筒冷却水排泄畅通，加强了钢丝经拉拔后的冷却，确保拉拔后钢丝的强度；

LSJ series gearbox and water plate adopt integrated design. The inner of water plate has a back-water hole and the outer with inlet hole to make sure the cooling water of the drum discharged freely, and strengthen the wire cooling and assures the wire strength after drawing.

LSJ系列减速机设有进油孔，放油孔，油镜孔，通气孔，便于减速机的使用维护；内部采用完全油润滑，确保滚动部件的充分润滑效果；

LSJ series gearbox has oil filler, oil drain, oil sight glass and breather, which is convenient for gearbox maintenance. Internal of the gearbox uses complete oil lubrication to ensure sufficient lubrication of the rolling parts.

LSJ系列减速机采用行星结构，高效率，高输出扭矩，高承载能力，且运转平稳，增强了钢丝爬罐的良好性能；

LSJ series reducer adopts planetary structure with high efficiency, high output torque, high load capacity and smooth operation. It guarantees good climb of steel wire on drawing capstan.

LSJ系列减速机输入部位采用卸荷结构，保证输入轴没有径向力，只承受纯扭矩，大大提高输入部位油封的使用寿命；

LSJ series reducer's input parts use unloading structure to ensure that no radial force on the input shaft and only bear torque which will increase the input part oil seal service life;

LSJ系列减速机只需加工机架上水盘安装孔即可整体快速安装，卸去皮带即可从机架上吊起减速机，利于安装和检修；

LSJ series reducer can be easily installed by machining mounting holes on the water plate. Remove belt and lift the gearbox from base frame, it is convenient for installation and maintenance.

LSJ 系列拉丝机专用减速机
LSJ series reducer for drawing machine

注油接水孔示意图
Oiling-Water Filler Sketch

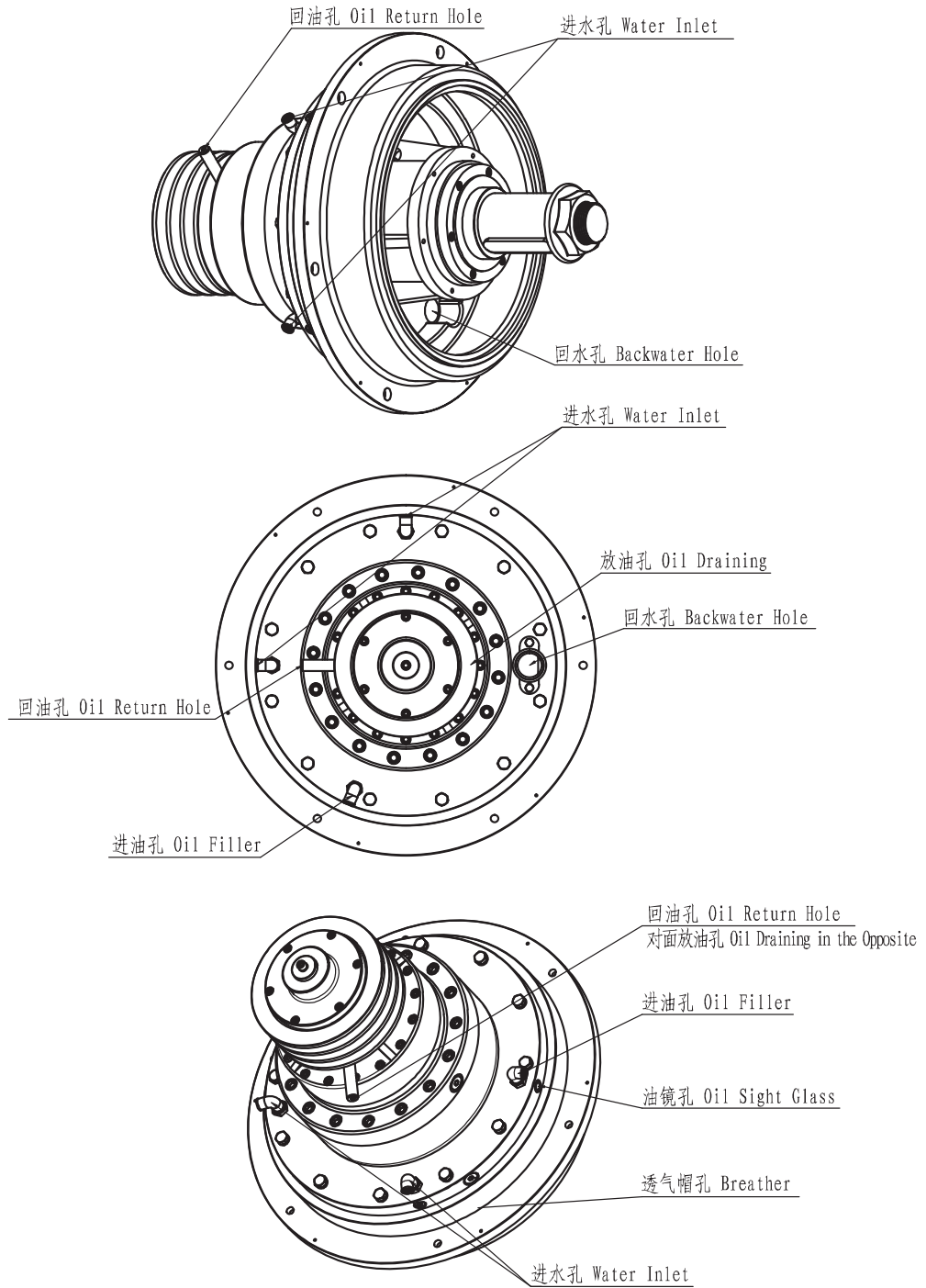

LSJ28-1E 拉丝机专用减速机
Wire Drawing Machine Gearbox

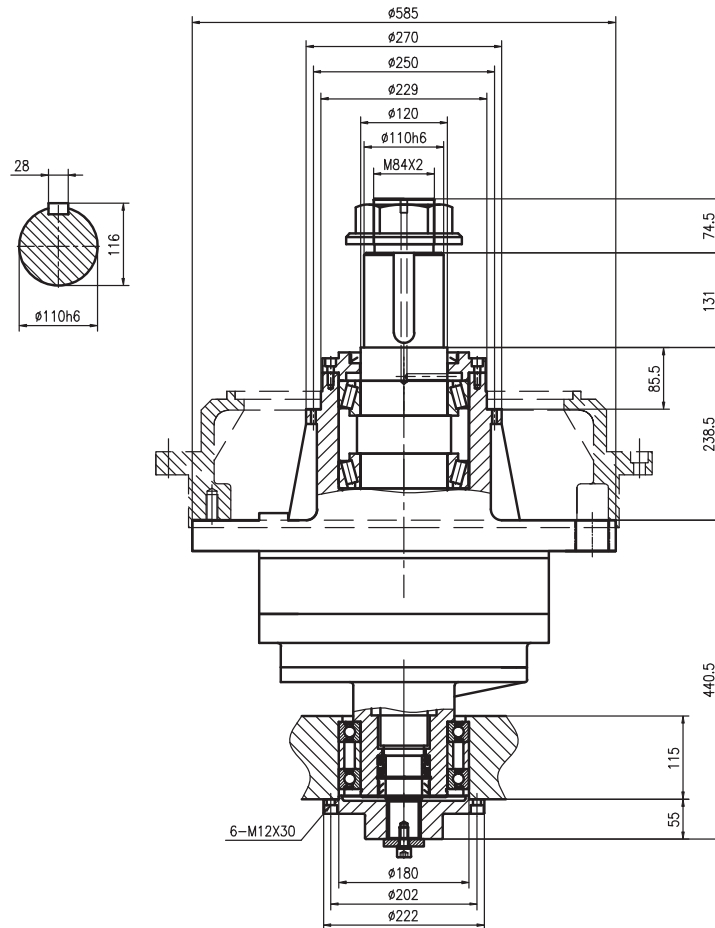

LSJ28 拉丝机专用减速机技术数据 Wire Drawing Machine Gearbox Technical Data

型号 Model	速比 Ratio	电机功率 (4P) Motor Power	输入皮带轮速比 Belt Pulley Ratio	拉拔道次 Drawing No.	标配卷筒 Diameter of Capstan
LSJ28-1E	5.43	11-22KW	≤1.75	第2道以上	400-450 (mm)

卷筒可根据客户非标要求定制 The capstan can be customized according to customer's requirements.

管路接头 Plumbing fittings

名称 Designation	进水孔 Water Inlet	出水孔 Water Outlet	进油孔 Oil Filler	出油孔 Oil Draining	透气帽孔 Breather
规格 Size	客户定制 Customized	客户定制 Customized	G1/2	G1/2	G1/2
数量 Quantity			1	1	1

LSJ28-1E1L 拉丝机专用减速机
Wire Drawing Machine Gearbox

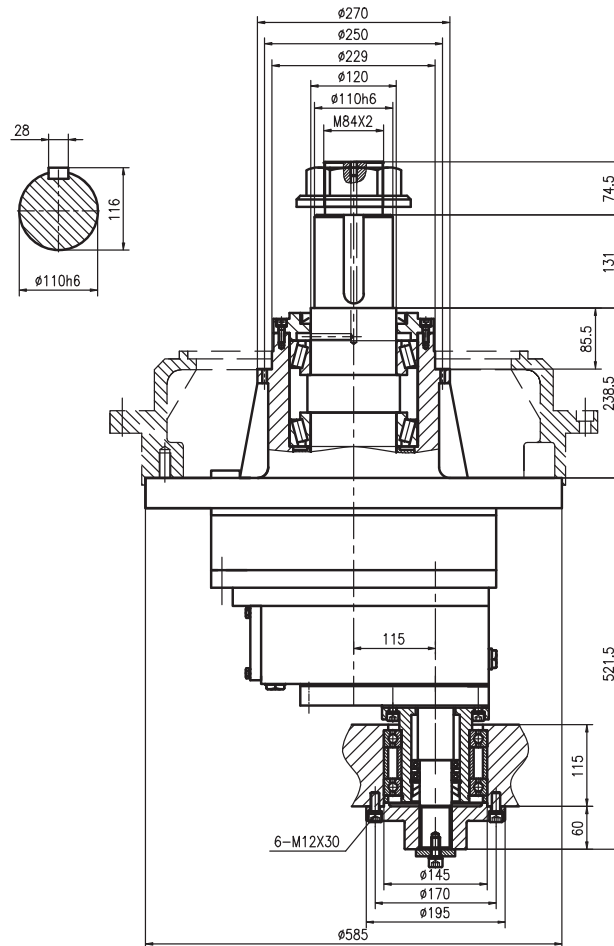

LSJ28 拉丝机专用减速机技术数据 Wire Drawing Machine Gearbox Technical Data

型号 Model	速比 Ratio	电机功率 (4P) Motor Power	输入皮带轮速比 Belt Pulley Ratio	拉拔道次 Drawing No.	标配卷筒 Diameter of Capstan
LSJ28-1E1L	5.43-25	11-22KW	≤1.75	第2道以上	400-450 (mm)

卷筒可根据客户非标要求定制 The capstan can be customized according to customer's requirements.

管路接头 Plumbing fittings

名称 Designation	进水孔 Water Inlet	出水孔 Water Outlet	进油孔 Oil Filler	出油孔 Oil Draining	透气帽孔 Breather
规格 Size	客户定制 Customized	客户定制 Customized	G1/2	G1/2	G1/2
数量 Quantity			1	1	1

LSJ28-2E 拉丝机专用减速机
Wire Drawing Machine Gearbox

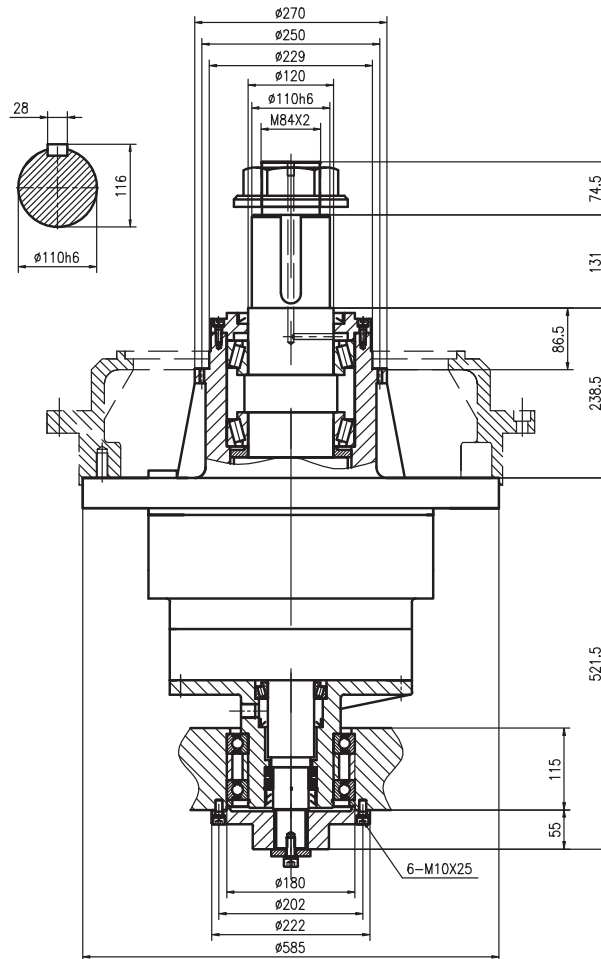

LSJ28 拉丝机专用减速机技术数据 Wire Drawing Machine Gearbox Technical Data

型号 Model	速比 Ratio	电机功率 (4P) Motor Power	输入皮带轮速比 Belt Pulley Ratio	拉拔道次 Drawing No.	标配卷筒 Diameter of Capstan
LSJ28-2E	25/28/31.5/35.5/40	11-22KW	≤ 1.75	第1道	400-450 (mm)

卷筒可根据客户非标要求定制 The capstan can be customized according to customer's requirements.

管路接头 Plumbing fittings

名称 Designation	进水孔 Water Inlet	出水孔 Water Outlet	进油孔 Oil Filler	出油孔 Oil Draining	透气帽孔 Breather
规格 Size	客户定制 Customized	客户定制 Customized	G1/2	G1/2	G1/2
数量 Quantity			1	1	1

LSJ48-1E 拉丝机专用减速机
Wire Drawing Machine Gearbox

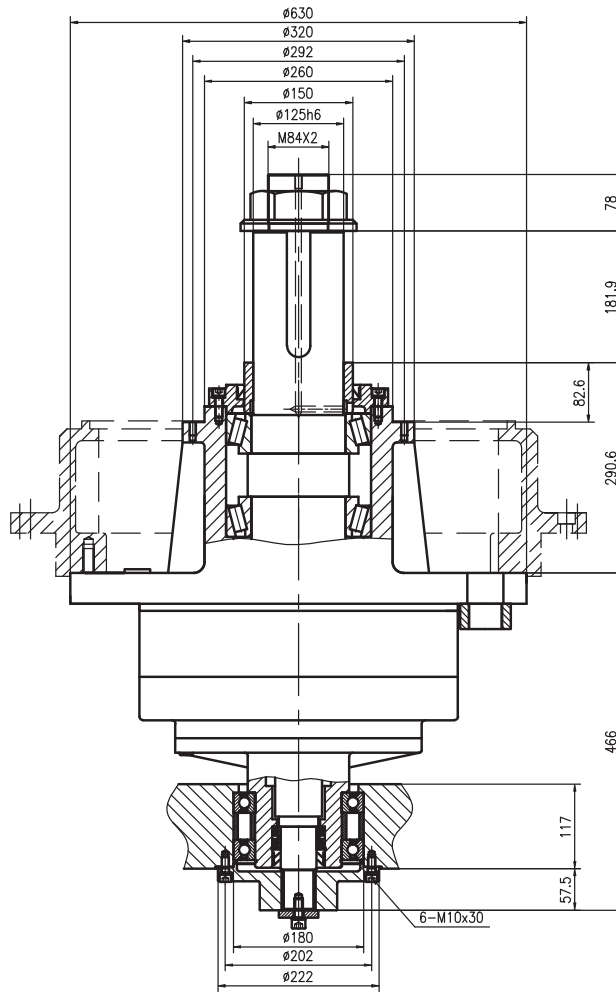

LSJ48 拉丝机专用减速机技术数据 Wire Drawing Machine Gearbox Technical Data

型号 Model	速比 Ratio	电机功率 (4P) Motor Power	输入皮带轮速比 Belt Pulley Ratio	拉拔道次 Drawing No.	标配卷筒 Diameter of Capstan
LSJ48-1E	5.43	30-55KW	≤ 1.75	第2道以上	500-600 (mm)

卷筒可根据客户非标要求定制 The capstan can be customized according to customer's requirements.

管路接头 Plumbing fittings

名称 Designation	进水孔 Water Inlet	出水孔 Water Outlet	进油孔 Oil Filler	出油孔 Oil Draining	透气帽孔 Breather
规格 Size	客户定制 Customized	客户定制 Customized	G1/2	G1/2	G1/2
数量 Quantity			1	1	1

LSJ48-1E1L 拉丝机专用减速机
Wire Drawing Machine Gearbox

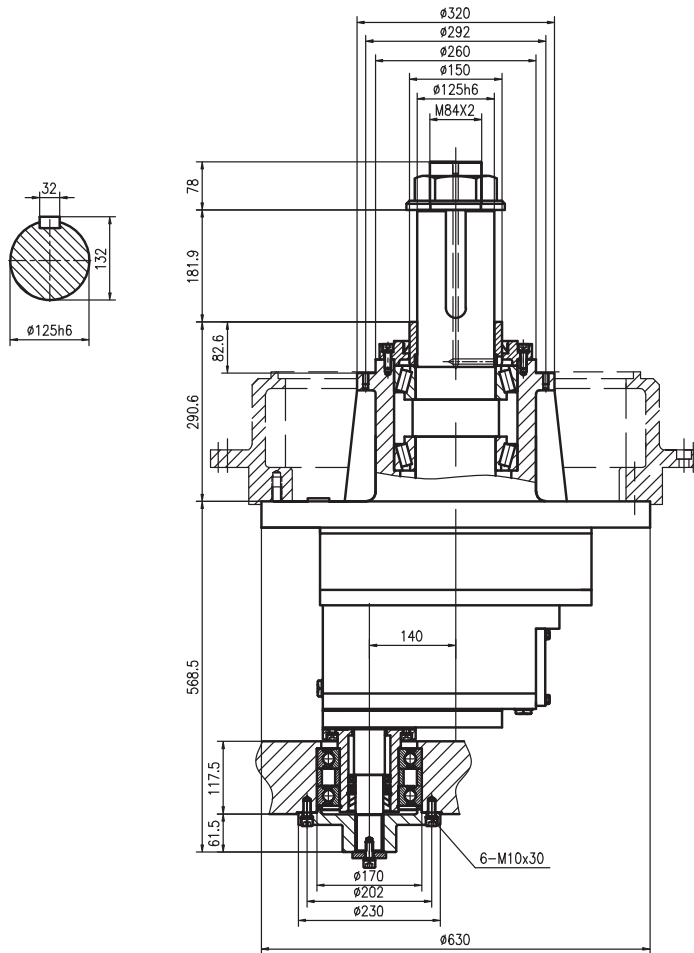

LSJ48 拉丝机专用减速机技术数据 Wire Drawing Machine Gearbox Technical Data

型号 Model	速比 Ratio	电机功率 (4P) Motor Power	输入皮带轮速比 Belt Pulley Ratio	拉拔道次 Drawing No.	标配卷筒 Diameter of Capstan
LSJ48-1E1L	5.43-25	30-55KW	≤ 1.75	第2道以上	500-600 (mm)

卷筒可根据客户非标要求定制 The capstan can be customized according to customer's requirements.

管路接头 Plumbing fittings

名称 Designation	进水孔 Water Inlet	出水孔 Water Outlet	进油孔 Oil Filler	出油孔 Oil Draining	透气帽孔 Breather
规格 Size	客户定制 Customized	客户定制 Customized	G1/2	G1/2	G1/2
数量 Quantity			1	1	1

LSJ48-2E 拉丝机专用减速机
Wire Drawing Machine Gearbox

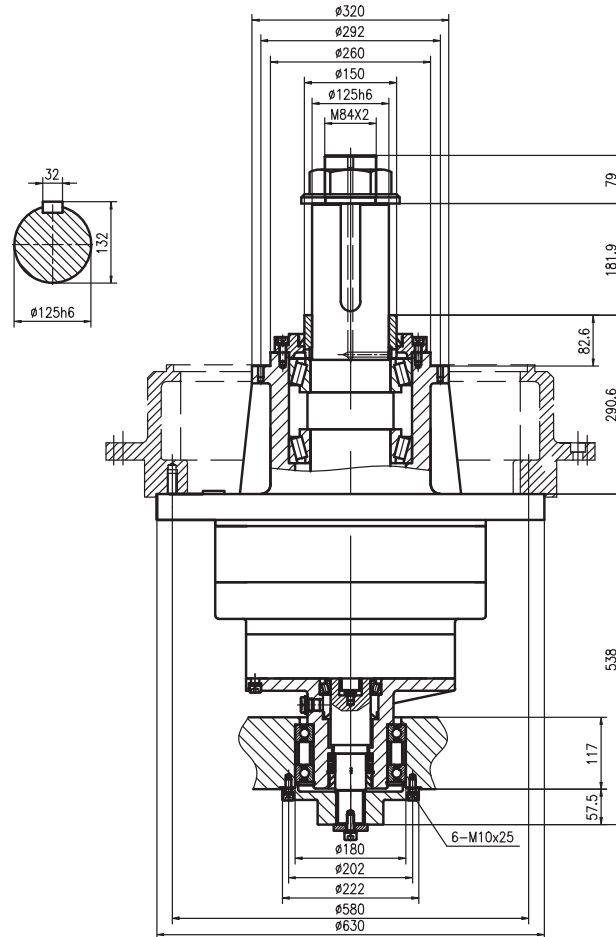

LSJ48 拉丝机专用减速机技术数据 Wire Drawing Machine Gearbox Technical Data

型号 Model	速比 Ratio	电机功率 (4P) Motor Power	输入皮带轮速比 Belt Pulley Ratio	拉拔道次 Drawing No.	标配卷筒 Diameter of Capstan
LSJ48-2E	25/28/31.5/35.5/40	30-55KW	≤ 1.75	第1道	500-600 (mm)

卷筒可根据客户非标要求定制 The capstan can be customized according to customer's requirements.

管路接头 Plumbing fittings

名称 Designation	进水孔 Water Inlet	出水孔 Water Outlet	进油孔 Oil Filler	出油孔 Oil Draining	透气帽孔 Breather
规格 Size	客户定制 Customized	客户定制 Customized	G1/2	G1/2	G1/2
数量 Quantity			1	1	1

LSJ68-1E 拉丝机专用减速机
Wire Drawing Machine Gearbox

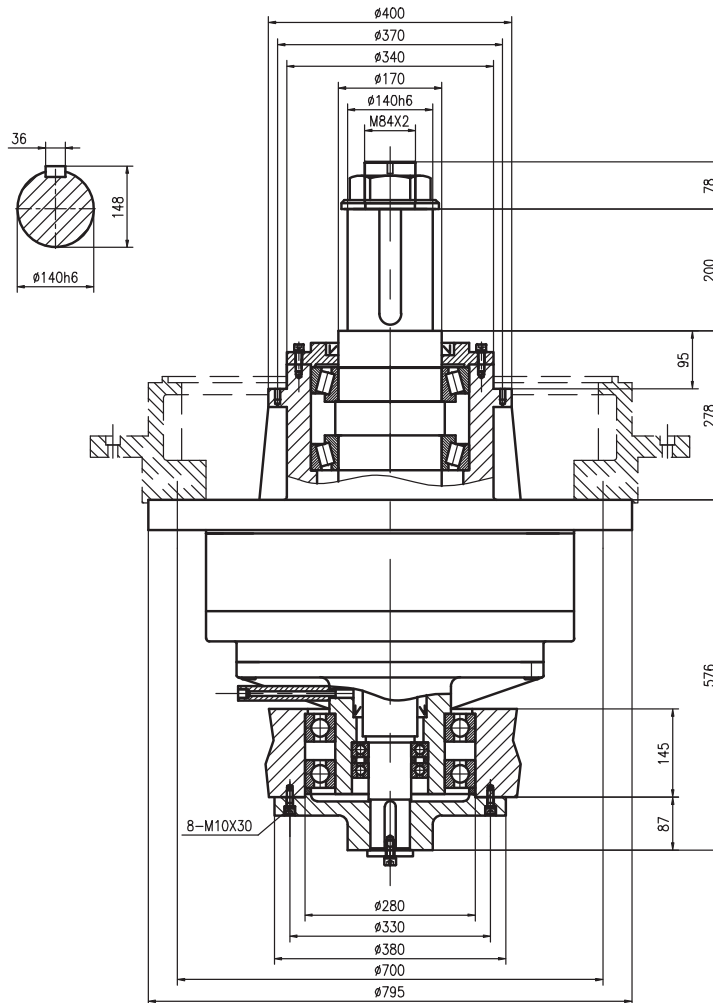

LSJ68 拉丝机专用减速机技术数据 Wire Drawing Machine Gearbox Technical Data

型号 Model	速比 Ratio	电机功率 (4P) Motor Power	输入皮带轮速比 Belt Pulley Ratio	拉拔道次 Drawing No.	标配卷筒 Diameter of Capstan
LSJ68-1E	5.29	75KW	≤1.75	第2道以上	700-900 (mm)

卷筒可根据客户非标要求定制 The capstan can be customized according to customer's requirements.

管路接头 Plumbing fittings

名称 Designation	进水孔 Water Inlet	出水孔 Water Outlet	进油孔 Oil Filler	出油孔 Oil Draining	透气帽孔 Breather
规格 Size	客户定制 Customized	客户定制 Customized	G1	G3/4	G1/2
数量 Quantity			1	1	1

LSJ68-1E1L 拉丝机专用减速机
Wire Drawing Machine Gearbox

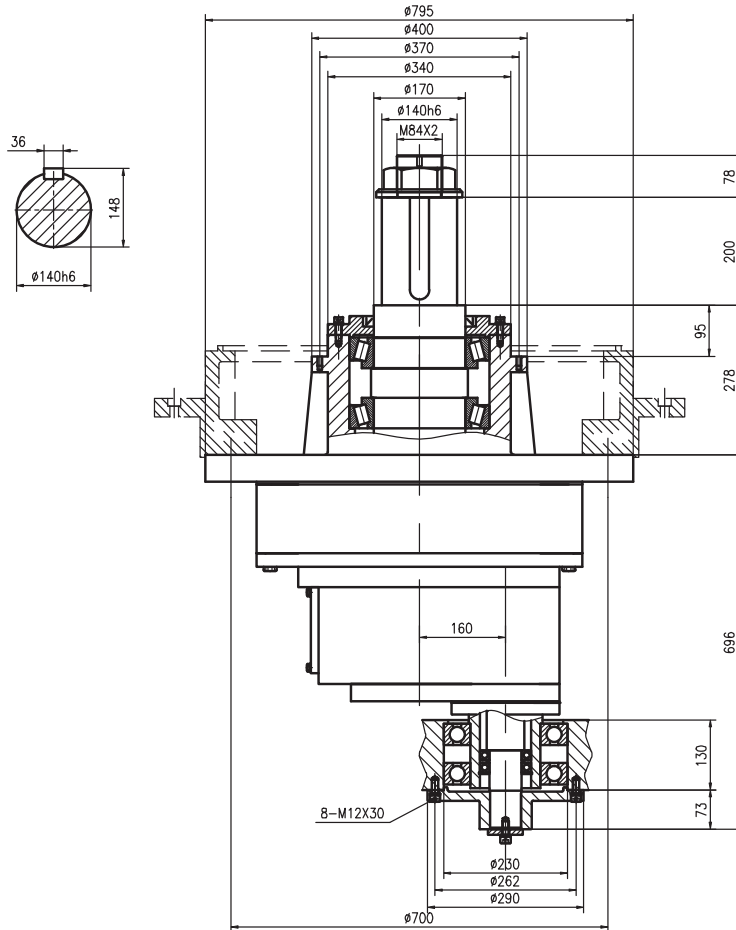

LSJ68 拉丝机专用减速机技术数据 Wire Drawing Machine Gearbox Technical Data

型号 Model	速比 Ratio	电机功率 (4P) Motor Power	输入皮带轮速比 Belt Pulley Ratio	拉拔道次 Drawing No.	标配卷筒 Diameter of Capstan
LSJ68-1E1L	5.29-25	75KW	≤1.75	第2道以上	700-900 (mm)

卷筒可根据客户非标要求定制 The capstan can be customized according to customer's requirements.

管路接头 Plumbing fittings

名称 Designation	进水孔 Water Inlet	出水孔 Water Outlet	进油孔 Oil Filler	出油孔 Oil Draining	透气帽孔 Breather
规格 Size	客户定制 Customized	客户定制 Customized	G1	G3/4	G1/2
数量 Quantity			1	1	1

LSJ68-2E 拉丝机专用减速机
Wire Drawing Machine Gearbox

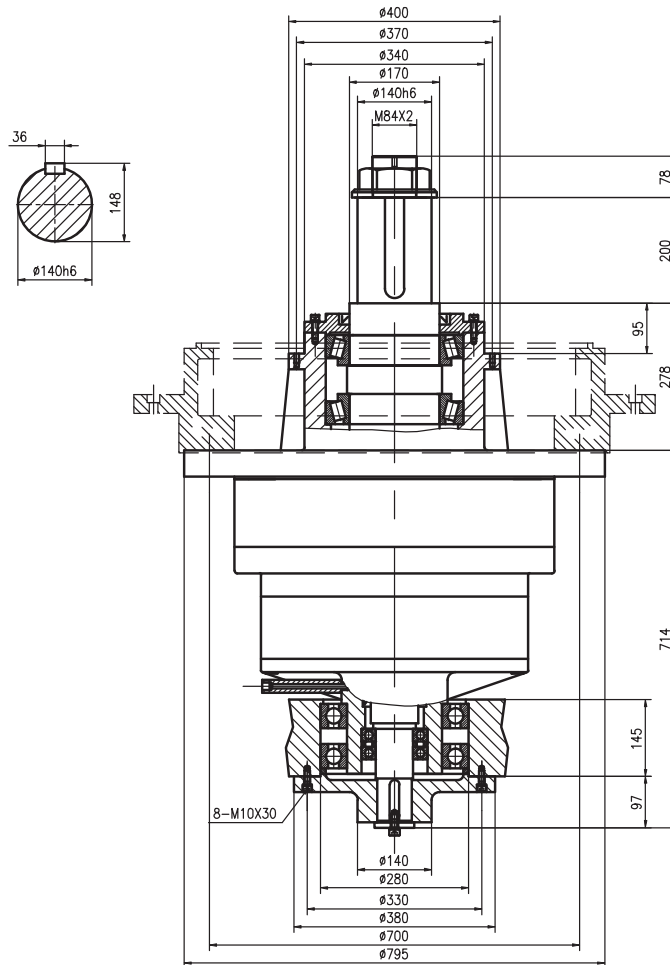

LSJ68 拉丝机专用减速机技术数据 Wire Drawing Machine Gearbox Technical Data					
型号 Model	速比 Ratio	电机功率 (4P) Motor Power	输入皮带轮速比 Belt Pulley Ratio	拉拔道次 Drawing No.	标配卷筒 Diameter of Capstan
LSJ68-2E	25/28/31.5/35.5/40	75KW	≤1.75	第1道	700-900 (mm)

卷筒可根据客户非标要求定制 The capstan can be customized according to customer's requirements.

管路接头 Plumbing fittings					
名称 Designation	进水孔 Water Inlet	出水孔 Water Outlet	进油孔 Oil Filler	出油孔 Oil Draining	透气帽孔 Breather
规格 Size	客户定制 Customized	客户定制 Customized	G1	G3/4	G1/2
数量 Quantity			1	1	1

LSJ108-1E 拉丝机专用减速机
Wire Drawing Machine Gearbox

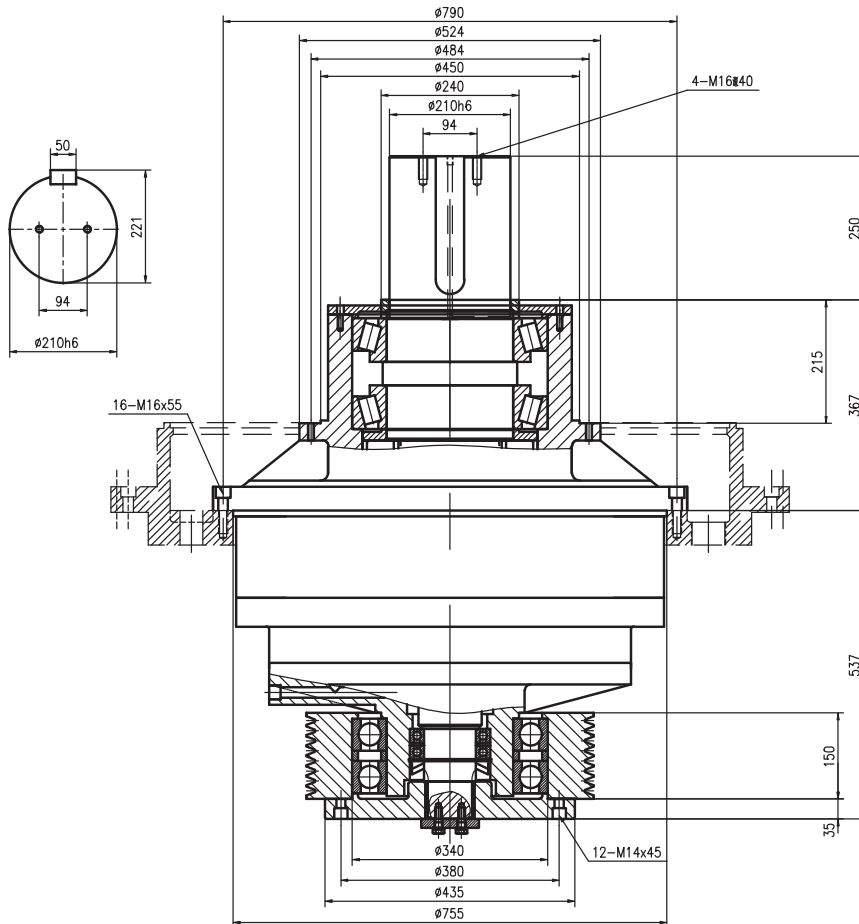

LSJ108 拉丝机专用减速机技术数据 Wire Drawing Machine Gearbox Technical Data

型号 Model	速比 Ratio	电机功率 (4P) Motor Power	输入皮带轮速比 Belt Pulley Ratio	拉拔道次 Drawing No.	标配卷筒 Diameter of Capstan
LSJ108-1E	4/5.25	90-110KW	≤ 1.75	第2道以上	1000-1200 (mm)

卷筒可根据客户非标要求定制 The capstan can be customized according to customer's requirements.

管路接头 Plumbing fittings

名称 Designation	进水孔 Water Inlet	出水孔 Water Outlet	进油孔 Oil Filler	出油孔 Oil Draining	透气帽孔 Breather
规格 Size	客户定制 Customized	客户定制 Customized	G1	G3/4	G1/2
数量 Quantity			1	1	1

LSJ108-2E 拉丝机专用减速机
Wire Drawing Machine Gearbox

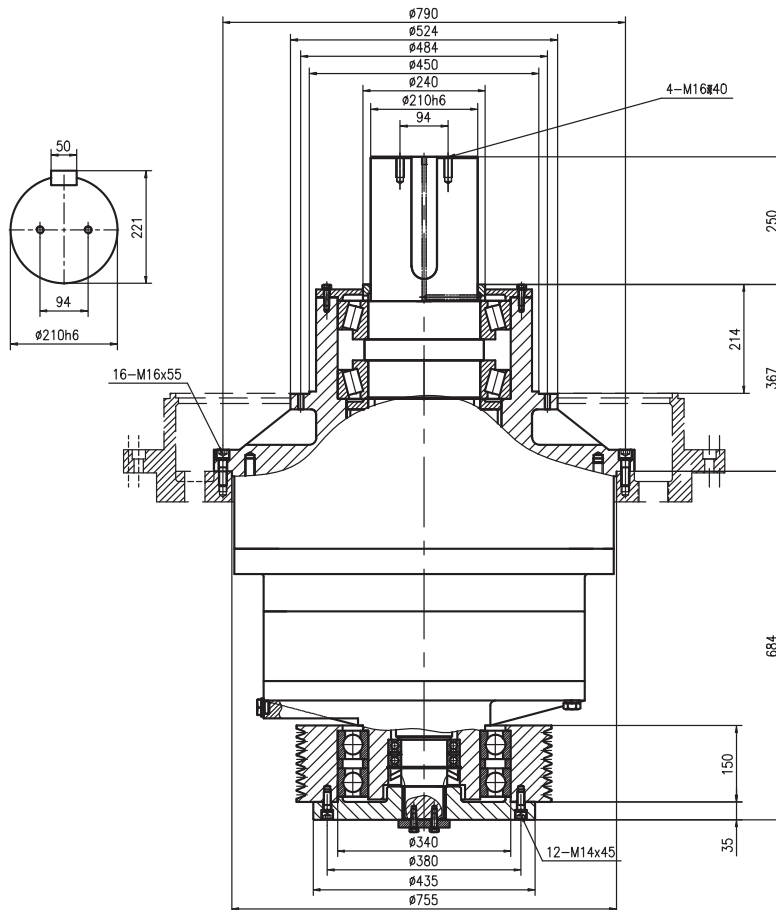

LSJ108 拉丝机专用减速机技术数据 Wire Drawing Machine Gearbox Technical Data

型号 Model	速比 Ratio	电机功率 (4P) Motor Power	输入皮带轮速比 Belt Pulley Ratio	拉拔道次 Drawing No.	标配卷筒 Diameter of Capstan
LSJ108-2E	15.5/18.664/20.34/25	90-110KW	≤1.75	第2道以上	1000-1200 (mm)

卷筒可根据客户非标要求定制 The capstan can be customized according to customer's requirements.

管路接头 Plumbing fittings

名称 Designation	进水孔 Water Inlet	出水孔 Water Outlet	进油孔 Oil Filler	出油孔 Oil Draining	透气帽孔 Breather
规格 Size	客户定制 Customized	客户定制 Customized	G1	G3/4	G1/2
数量 Quantity			1	1	1

LSJ108-3E 拉丝机专用减速机
Wire Drawing Machine Gearbox

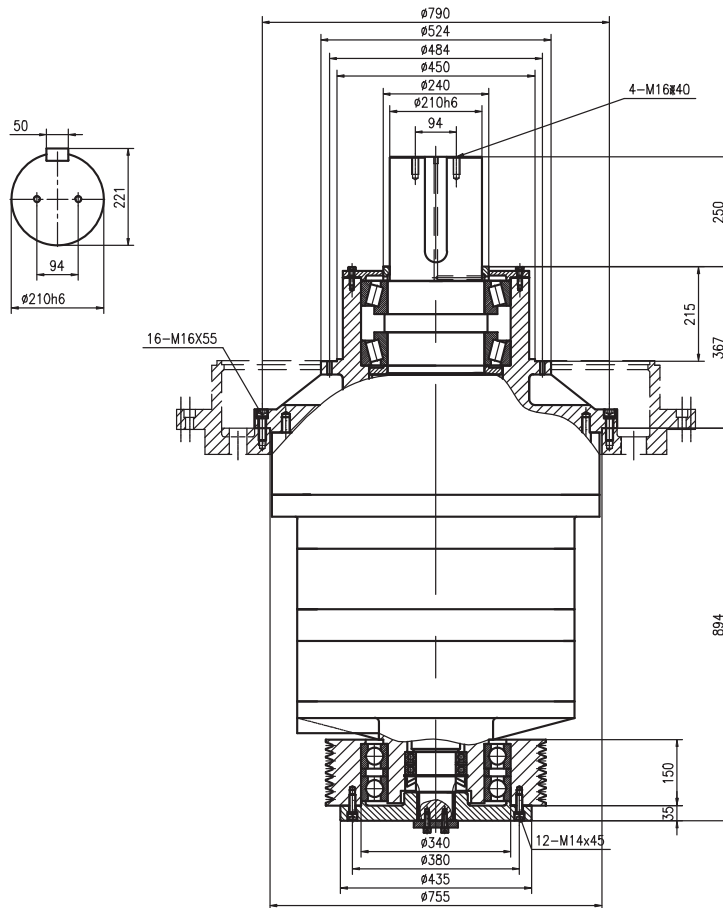

LSJ108 拉丝机专用减速机技术数据 Wire Drawing Machine Gearbox Technical Data					
型号 Model	速比 Ratio	电机功率 (4P) Motor Power	输入皮带轮速比 Belt Pulley Ratio	拉拔道次 Drawing No.	标配卷筒 Diameter of Capstan
LSJ108-3E	60.06/63.4/78.8	90-110KW	≤1.75	第1道	1000-1200 (mm)

卷筒可根据客户非标要求定制 The capstan can be customized according to customer's requirements.

管路接头 Plumbing fittings					
名称 Designation	进水孔 Water Inlet	出水孔 Water Outlet	进油孔 Oil Filler	出油孔 Oil Draining	透气帽孔 Breather
规格 Size	客户定制 Customized	客户定制 Customized	G1	G3/4	G1/2
数量 Quantity			1	1	1